

1-needle, Lockstitch, Zigzag Stitching Machine with Large Hook

LZH-1290

LZH-1290-7 (with automatic thread trimmer)

- With its newly incorporated triangular cam, the machine uniformly tenses thread in zigzag strokes regardless of the needle position, and the needle always enters the material at right angles. This prevents the needle from swaying during zigzag stitching.
- The machine offers outstanding capabilities for the sewing of sports shoes and leather shoes that require a wider zigzag width. The zigzag width can be quickly and easily adjusted by the dial mounted on the front face of the machine.
- To ensure smooth sewing of heavy materials, the lift of the presser foot is as high as 14mm (13mm for the LZH-1290-7).
- By reducing the frequency of bobbin thread replacement, the newly introduced horizontal-axis double-capacity hook contributes to increased efficiency in sewing. This feature is extremely helpful when sewing with thick thread.
- **LZH-1290-7**
The machine's unique thread trimmer mechanism allows the thread trimmer to cut the thread when the needle is either at the left or right end of its zigzag stroke. This mechanism also eliminates the need for adjustment even when the thread count is changed.

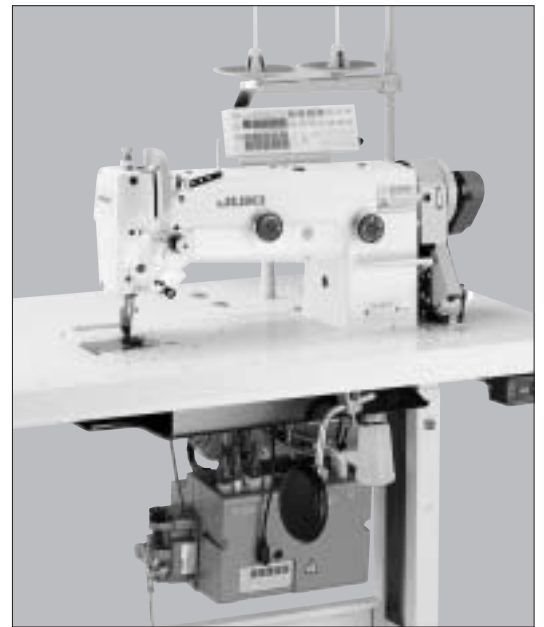

LZH-1290-7-0B/XC-E500



SPECIFICATIONS

Model name	LZH-1290	LZH-1290-7
Max. sewing speed	2,000rpm	
Max. stitch length	6mm (normal/reverse feed)	
Zigzag width	Max. 8mm (adjustable to 10mm)	
Zigzag width adjustment method	By dial	
Needle bar stroke	35mm	
Lift of the presser foot	By hand: 6mm, By knee: 14mm	By hand: 6mm, By knee: 13mm
Thread take-up	Link type	
Hook	Horizontal-axis full-rotary double-capacity hook	
Needle (at the time of delivery)	SY1906 (Nm110) Nm90 ~ Nm110	
Thread	#50 ~ #8, B33 ~ B92, Nm=120/3 ~ 30/3	
Lubrication	By an oiler (hook: automatic)	
Lubricating oil	JUKI New Defrix Oil No.1 (equivalent to ISO VG7)	
Distance from needle to machine arm	295mm	
Bed size	477mm x 178mm	
Weight of the machine head	35kg	39kg
Automatic reverse feed function	Provide as standard	
Power requirement	Single-phase 100 ~ 120V, 220 ~ 240V, 3-phase 200 ~ 220V, 220 ~ 240V	

WHEN YOU PLACE ORDERS

● Without automatic thread trimmer

LZH1290

● With automatic thread trimmer

LZH129070B/

Pneumatic auto-lifter	Code
Not provided	
Knee switch type (AK112C)	C
Pedal switch type (AK112B)	B

● Motor for SC

M

Motor			Code
For General Export	Single-phase 3-phase	200 ~ 240V	60
For JUS (LA) *	Single-phase	100 ~ 120V	61
	3-phase	200 ~ 240V	62
For CE	Single-phase	200 ~ 240V	63

● PSC box/operation panel for SC

SC380

PSC box			Code
For General Export	Single-phase	220 ~ 240V	07
	3-phase	200 ~ 220V	11
For JUS (LA) *	Single-phase	110 ~ 120V	37
	3-phase	220 ~ 240V	38
For CE	Single-phase	220 ~ 240V	34

Operation panel		Code
Not provided		00000
Operation panel display language: English. Instruction manual comes in three different languages.		E500B
Operation panel display language: English. Instruction manual comes in five different languages.		E500C

* JUS: North America and Central and South America.

GAUGE

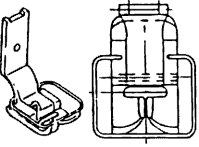
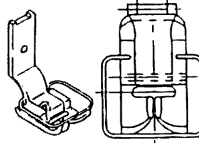
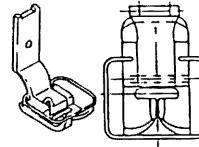
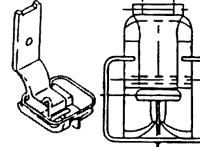
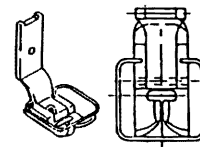
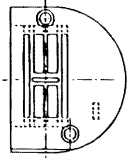
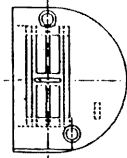
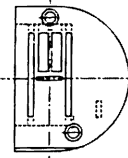
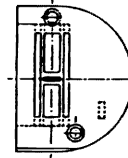
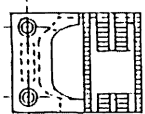
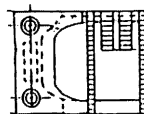
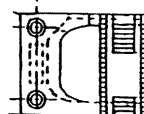
Type	Standard	For frictional* material	For zigzag* width of 10mm	Provided with* a center guide	3-row feed dog*
Presser foot	100-86353 	100-86379 (pearl-bright finish) 	100-85751 	100-98051 	100-85850 
Throat plate	100-93300 		100-75505 	100-93318 	100-75711 
Feed dog	100-83301 			110-83319 	100-83525 
Remarks	Zigzag width: Max. 8mm	Zigzag width: Max. 8mm The pearl-bright finish presser foot has the same surface smoothness as the teflon-finish type, but its rigidity is markedly superior.	Zigzag width: Max. 10mm	Zigzag width: Max. 8mm	Zigzag width: Max. 6mm

* Gauges other than the standard one are optionally available.